

LUBRICATE ALL SEALS WITH CLEAN HYDRAULIC OIL PRIOR TO ASSEMBLY. DO NOT USE SILICONE BASED LUBRICANTS.

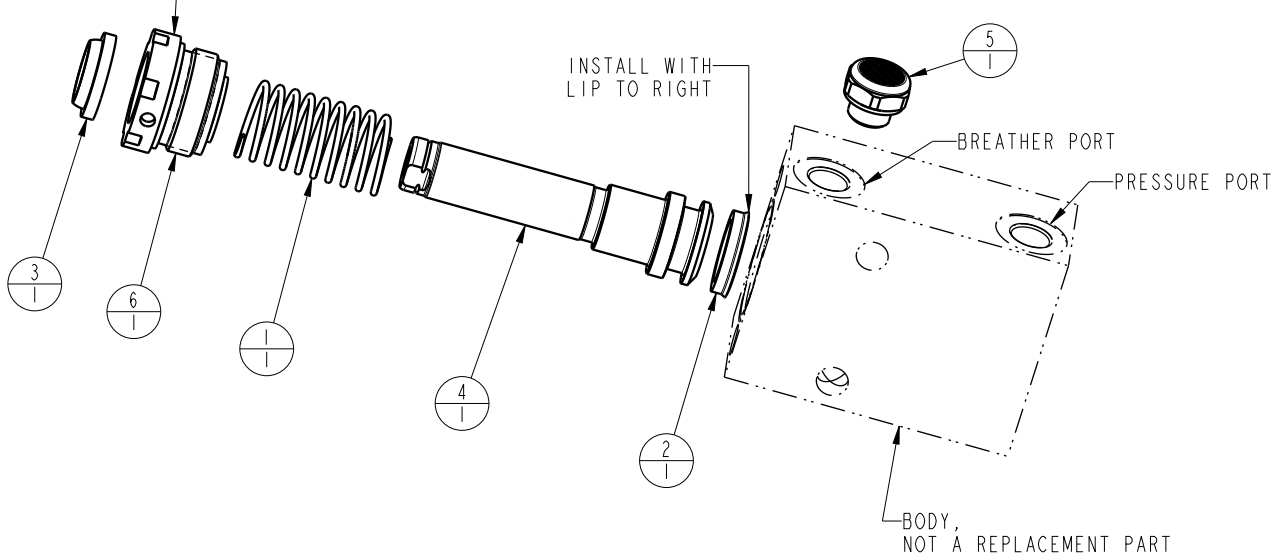

TIGHTEN TO 75 Nm TORQUE ( 55 FT-LBS )  
 USE VEKTEK TORQUE TOOL  
 NEW STYLE TORQUE TOOL AT200081, 6 POINTED TOOL (CIRCA 2018)  
 OLD STYLE TORQUE TOOL AT200080, 2 POINTED SPANNER HOLE TOOL



N/A	N/A	61201108	KIT, SPRING	N/A	N/A	NOTED
N/A	N/A	6V201108	KIT, SEAL, FKM	N/A	NOTED	N/A
N/A	N/A	46000035	KIT, SEAL, STANDARD	NOTED	N/A	N/A
6	1	82030802	GLAND, CYL, BB, DA, 2200			
5	1	49001904	BREATHER, 1/8 BSPP			
4	1	48010800	PISTON, CYL, BB, 10.1KN, 19 STRK			
3	1	39012011	WIPER, SNAP-IN, (1/2)	X	X	
2	1	39010013	SEAL, BEVEL, 9/16 X 3/32 X 3/4	X	39012000	
1	1	23313006	SPRING, COMPRESSION			X
No.	QTY	PART No.	DESCRIPTION	Standard Seal Kit	FKM Seal Kit	Spring Kit

### PARTS LIST

ASSEMBLIES AFFECTED  
42011001

VEKTEK, INC.  
 1334 E. SIXTH AVE. P.O. BOX 625  
 EMPORIA, KS. 66801 U.S.A.

REV	IN ACCORDANCE WITH ECN	EFFECTIVE DATE	REVISED BY	DATE
DATE:	12/15/94	DRAWING STATUS: <b>Released</b> PRODUCTION APPROVED FOR RELEASED STATUS ONLY		

SIZE  
A

## MPL2044

REV  
H

FORM FEG035\_PL\_ASIZE, REV. B

H	4249	RELEASE	JDW	08/03/20
REV	IN ACCORDANCE WITH ECN	EFFECTIVE DATE	REVISED BY	DATE
DATE:	12/15/94	DRAWING STATUS: <b>Released</b> PRODUCTION APPROVED FOR RELEASED STATUS ONLY		